

# B SERIES

## AUTOMATIC OVERWRAPPER



### B SERIES

OVERWRAPPING MACHINERY



### FEATURES:

- Diverse pack size and type capability
- 4 line multi-language diagnostic display
- Ease of use
- Low maintenance and running costs
- Integral, variable speed conveyor
- AC inverter and geared motor drive
- Positive in-line mechanical film draw
- Envelope end fold wrap and concealed base overlap
- Low level film spindle for ease of loading
- Supplied on castors for manoeuvrability

### OPTIONAL FEATURES:

- Automatic collator
- Tear tape applicator with extended tab for easy opening
- Print registration unit
- Any conveyor and control handling combination
- Product handling systems, coders and labellers
- Sleeve wrap and full overwrap capability
- Uncoated paper overwrap with cold glue for seals
- Film slitter with powered waste film winding system



# B SERIES

## AUTOMATIC OVERWRAPPER

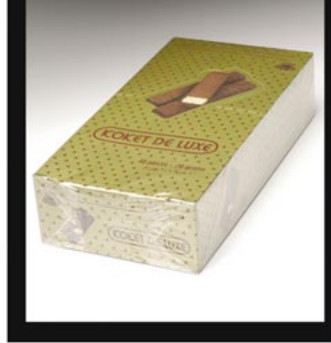

B SERIES

OVERWRAPPING MACHINERY

### OPERATING PRINCIPLE

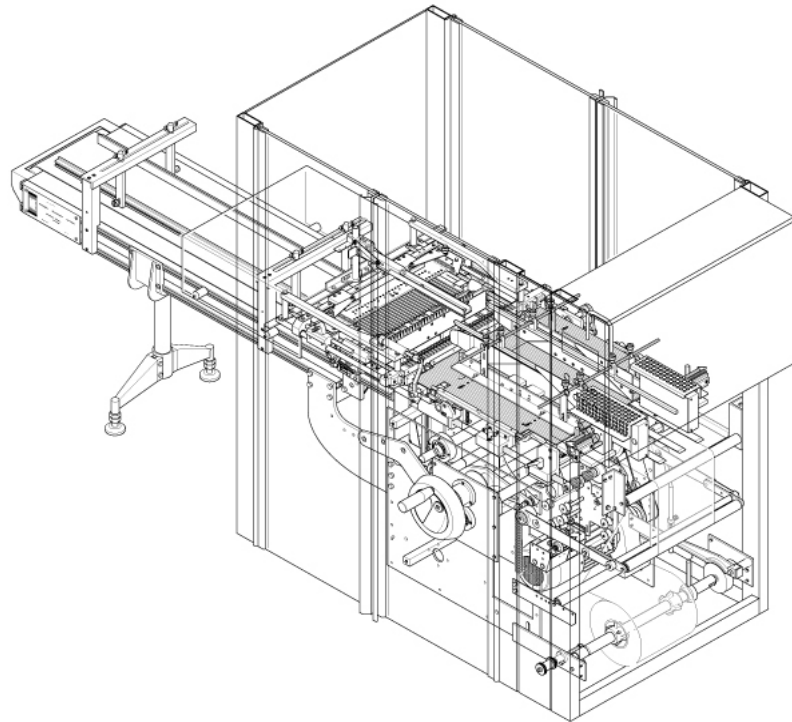
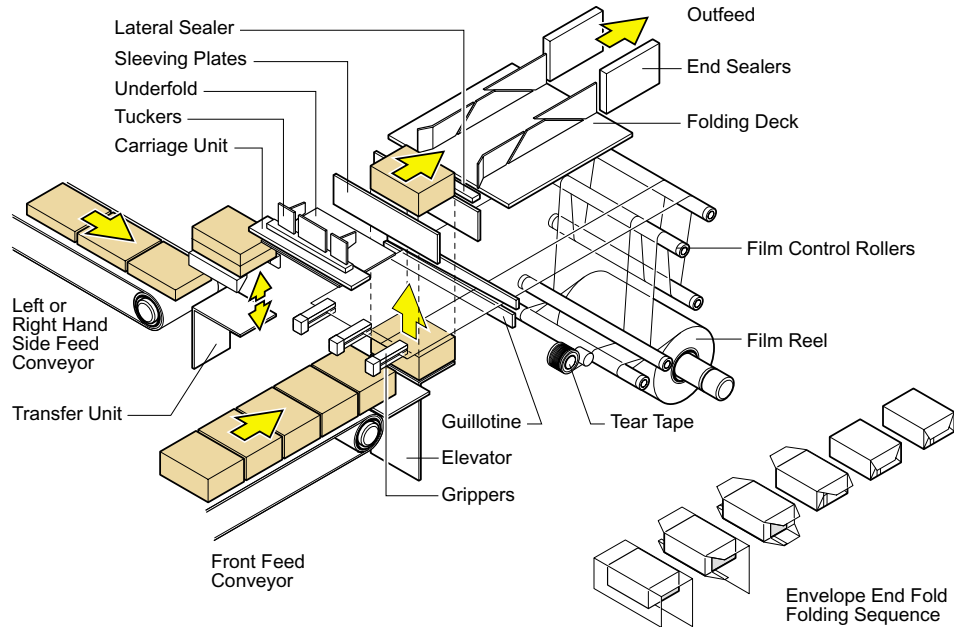

#### TECHNICAL DATA :

**Film length:** 80 - 865 mm  
**Film width:** 75 - 554 mm  
Film widths and lengths outside this range can be achieved by special design

**Wrap material:** Most heat sealable films and papers  
**Product size range:** Length: 50 - 450 mm  
Width: 22 - 350 mm  
Height: 10 - 175 mm

Product sizes outside this range can be accommodated by special design

**Size change time:** Approximately 30 minutes  
**Output:** Up to 50 packs per minute, depending on product size  
Greater output speeds can be achieved by special design



#### Marden Edwards Limited

2 Nimrod Way  
Ferndown Industrial Estate  
Wimborne Dorset  
United Kingdom  
Tel: +44 (0) 1202 861200  
Fax: +44 (0) 1202 861400

Email: [me@mardenedwards.com](mailto:me@mardenedwards.com)  
Web: [www.mardenedwards.com](http://www.mardenedwards.com)