

BX SERIES

AUTOMATIC OVERWRAPPER



BX SERIES

OVERWRAPPING MACHINERY



FEATURES:

- Diverse pack size and type capability
- 4 line multi-language diagnostic display
- Ease of use
- Low maintenance and running costs
- Integral, variable speed conveyor
- AC inverter and geared motor drive
- Positive in-line mechanical film draw
- Envelope end fold wrap and concealed base overlap
- Low level cantilevered film spindle for ease of loading
- Supplied on castors for manoeuvrability
- Film splicing deck
- High level quick access guards
- Fast and tool-less size change

OPTIONAL FEATURES:

- Automatic collator
- Tear tape applicator with extended tab for easy opening
- Print registration unit
- Any conveyor and control handling combination
- Product handling systems, coders and labellers
- Sleeve wrap and full overwrap capability
- Uncoated paper overwrap with cold glue for seals
- Additional cantilevered film spindle with low film warning
- Film slitter with powered waste film winding system



BX SERIES

AUTOMATIC OVERWRAPPER



BX SERIES

OVERWRAPPING MACHINERY

OPERATING PRINCIPLE

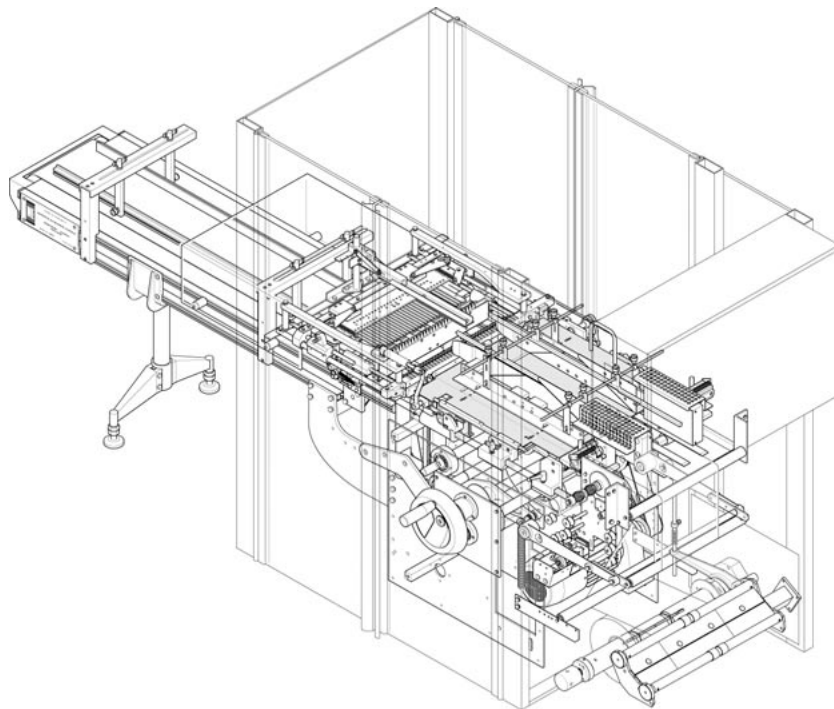
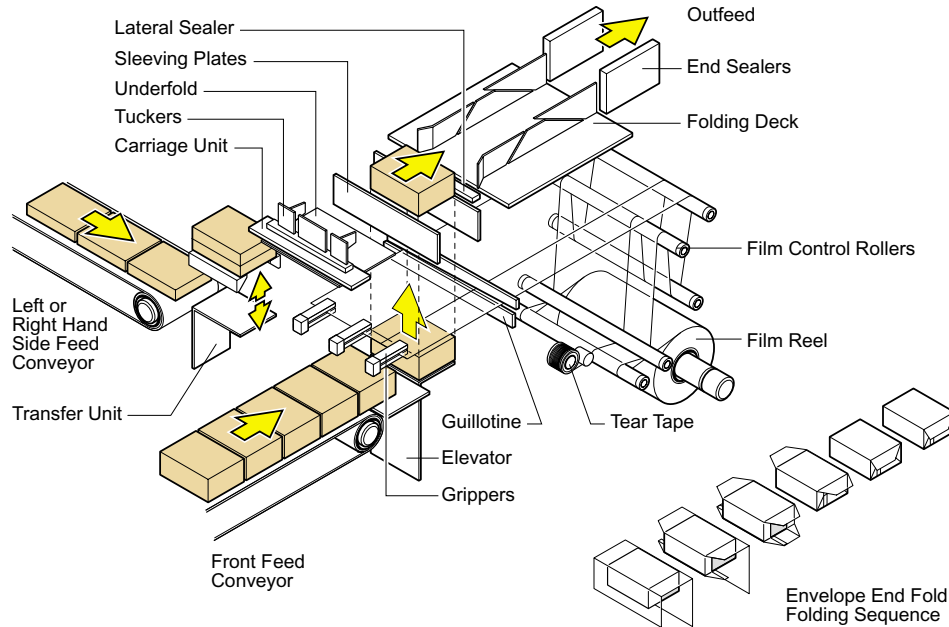

TECHNICAL DATA :

Film length: 80 - 865 mm
Film width: 75 - 554 mm
Film widths and lengths outside this range can be achieved by special design

Wrap material: Most heat sealable films and papers
Product size range: Length: 50 - 450 mm
Width: 22 - 350 mm
Height: 10 - 175 mm

Product sizes outside this range can be accommodated by special design

Size change time: Approximately 20 minutes
Output: Up to 50 packs per minute, depending on product size
Greater output speeds can be achieved by special design



Marden Edwards Limited

2 Nimrod Way
Ferndown Industrial Estate
Wimborne Dorset
United Kingdom
Tel: +44 (0) 1202 861200
Fax: +44 (0) 1202 861400

Email: me@mardenedwards.com
Web: www.mardenedwards.com